

Summary of Product Characteristics

1. Name of the medicinal product

Xyntha 1000 IU

2. Qualitative and quantitative composition

Antihemophilic Factor (Recombinant) [BDDrFVIII] Lyophilized Powder for Reconstitution in a Vial.

250, 500, 1000, or 2000 IU in single-use vials and one pre-filled diluent syringe containing 4 mL 0.9% Sodium Chloride for reconstitution*

For a full list of excipients, see section 6.1.

3. Pharmaceutical form

White Powder and solvent for solution for intravenous (IV) injection

Available as 250, 500, 1000, or 2000 IU in single-use vials or as 250, 500, 1000, 2000 or 3000 IU in single-use prefilled dual-chamber syringe.

4. Clinical particulars

4.1 Therapeutic indications

Xyntha, Antihemophilic Factor (Recombinant) [BDDrFVIII], indicated for the control and prevention of hemorrhagic episodes and for routine and surgical prophylaxis in patients with hemophilia A (congenital factor VIII deficiency or classic hemophilia).

Xyntha does not contain von Willebrand factor and hence is not indicated in von Willebrand's disease.

Geriatrics (65 years of age):

Clinical studies of Xyntha did not include sufficient numbers of subjects aged 65 and over to determine whether they respond differently from younger subjects. Other reported clinical experience has not identified differences in responses between the elderly and younger patients. As with any patient receiving Xyntha, dose selection for an elderly patient should be individualized.

Pediatrics:

Xyntha is appropriate for use in children of all ages, including newborns.

4.2 Posology and method of administration

Posology

Dosage and administration

Treatment with Xyntha should be initiated under the supervision of a physician experienced in the treatment of hemophilia A.

Xyntha is appropriate for use in adults and children including newborns.

Dosage and duration of treatment depend on the severity of the factor VIII deficiency, the location and extent of bleeding, and the patient's clinical condition. Individual patients may vary in their response to

factor VIII, achieving different levels of in vivo recovery and demonstrating different half-lives. Doses administered should be titrated to the patient's clinical response. In the presence of an inhibitor, higher doses or appropriate alternative treatment may be required.

Dosage adjustment for patients with renal or hepatic impairment has not been studied in clinical trials.

The number of units of factor VIII administered is expressed in International Units (IU), which are related to the current World Health Organization (WHO) international standard for factor VIII activity. Factor VIII activity in plasma is expressed either as a percentage (relative to normal human plasma) or in IU (relative to an International Standard for factor VIII in plasma).

One IU of factor VIII activity corresponds approximately to the quantity of factor VIII in one ml of normal human plasma. The calculation of the required dosage of factor VIII is based upon the empirical finding that, on average, 1 IU of factor VIII per kg body weight raises the plasma factor VIII activity by 2 IU/dl. The required dosage is determined using the following formula:

Required units = body weight (kg) x desired factor VIII rise (IU/dL or % of normal) x 0.5 (IU/kg per IU/dL)

Clinical data support the use of the one-stage clotting assay for monitoring Xyntha therapy.

The labeled potency of Xyntha is based on the European Pharmacopoeia chromogenic substrate assay in which the Pfizer In-House Recombinant Factor VIII Potency Reference Standard has been calibrated using a one-stage clotting assay. This method of potency assignment is intended to harmonize Xyntha with clinical monitoring using a one-stage clotting assay.

Precise monitoring of the replacement therapy by means of plasma factor VIII activity assay should be considered, particularly for surgical intervention.

Dosing for Bleeding and Surgery:

In the case of the following hemorrhagic events, consideration should be given to maintaining the factor VIII activity at or above the plasma levels (in % of normal or in IU/dL) for the indicated period, as outlined in the following table.

Table 2: Maintenance of Factor VIII Activity for Various Hemorrhagic Events

	Factor VIII Level Required (% or IU/dl)	Frequency of Doses (h)/ Duration of Therapy (d)
--	---	---

Minor Early hemarthrosis, superficial muscle or soft tissue and oral bleeds	20-40	Repeat every 12 to 24 hours as necessary until resolved. At least 1 day, depending upon the severity of the hemorrhage.
Moderate Hemorrhages into muscles. Mild head trauma capitus. Minor operations including tooth extraction. Hemorrhages into the oral cavity.	30-60	Repeat infusion every 12 - 24 hours for 3 - 4 days or until adequate hemostasis is achieved. For tooth extraction a single infusion plus oral antifibrinolytic therapy within 1 hour may be sufficient.
Major Gastrointestinal bleeding. Intracranial, intra- abdominal or intrathoracic hemorrhages. Fractures. Major operations.	60-100	Repeat infusion every 8 - 24 hours until threat is resolved or in the case of surgery, until adequate local hemostasis is achieved, then continue therapy for at least another 7 days.

Dosage for Prophylaxis

Xyntha has been administered prophylactically in a pivotal clinical trial in adolescent and adult previously treated patients at a dose of 30 + 5 IU/kg given 3 times weekly.

Inhibitors

Patients using factor VIII replacement therapy should be monitored for the development of factor VIII inhibitors. If expected factor VIII activity plasma levels are not attained, or if bleeding is not controlled with an appropriate dose, an assay should be performed to determine if a factor VIII inhibitor is present. In patients with factor VIII inhibitors, factor VIII therapy may not be effective and other therapeutic options should be considered. Management of such patients should be directed by physicians with experience in the care of patients with hemophilia.

Method of Administration

Patients should follow the specific reconstitution and administration procedures provided by their physicians. For instructions, patients should follow the recommendations in the below Administration and Reconstitution sections. The procedures below are provided as general guidelines for the reconstitution and administration of Xyntha.

Additional instructions are provided after Infusion section that detail the use of a Xyntha vial and a Xyntha Solofuse or multiple Xyntha Solofuse [see Combined Use of a Xyntha Vial Kit and a Xyntha Solofuse, and Multiple Xyntha Solofuse Reconstitution to a 10 cc or Larger Luer Lock Syringe].

Parenteral drug products should be inspected visually for particulate matter and discoloration prior to administration, whenever solution and container permit.

Xyntha Vial Kit:

Xyntha is administered by IV infusion after reconstitution of the lyophilized powder with the supplied pre-filled diluent (0.9% Sodium Chloride solution) syringe.

Xyntha Solofuse:

Xyntha Solofuse is administered by intravenous (IV) infusion after reconstitution of the freeze-dried powder with the diluent (0.9% Sodium Chloride). Both the Xyntha powder and the diluent are supplied within the prefilled dual-chamber syringe.

Reconstitution

Always wash your hands before performing the following procedures. Use germ-free methods during the preparation procedures.

components used in the mixing and injection of Xyntha should be used as soon as possible after opening their sterile containers to minimize unnecessary exposure to room air.

Xyntha Vial Kit:

Use only the materials provided in the Xyntha kit for dissolving the Xyntha powder with the sodium chloride diluent.

Xyntha is administered by intravenous injection after dissolving with the supplied diluent (0.9% sodium chloride) in the pre-filled syringe.

Note: If you use more than one vial of Xyntha per injection, each vial should be dissolved according to the following instructions. The empty syringe should be removed leaving the vial adapter in place, and a separate large luer lock syringe may be used to draw back the dissolved contents of each vial. Do not detach the diluent syringes or the large luer lock syringe until you are ready to attach the large luer lock syringe to the next vial adapter.

Xyntha Solofuse:

Note: If you use more than one vial and/or prefilled dual-chamber syringe of Xyntha per infusion, each vial and/or syringe should be reconstituted according to the instructions for that respective product kit. A separate 10 cc or larger luer lock syringe (not included in this kit) may be used to draw back the reconstituted contents of each vial or syringe.

Xyntha Vial Kit:

1. Allow the vial of freeze-dried Xyntha powder and the pre-filled diluent syringe to reach room temperature.
2. Remove the plastic flip-top cap from the Xyntha vial to expose the central portions of the rubber stopper.

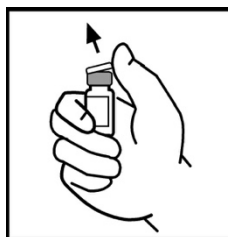

3. Wipe the top of the vial with the alcohol swab provided, or use another antiseptic solution, and allow to dry. After cleaning, do not touch the rubber stopper with your hand or allow it to touch any surface.
4. Peel back the cover from the clear plastic vial adapter package. Do not remove the adapter from the package.
5. Place the vial on a flat surface. While holding the adapter in the package, place the vial adapter over the vial. Press down firmly on the package until the adapter snaps into place on top of the vial, with the adapter spike penetrating the vial stopper.

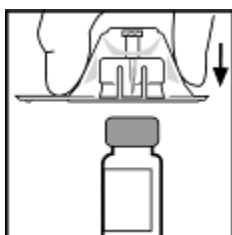

6. Grasp the plunger rod as shown in the diagram. Avoid contact with the shaft of the plunger rod. Attach the threaded end of the plunger rod to the diluent syringe by pushing and turning firmly.



7. Break off the tamper-resistant, plastic-tip cap from the diluent syringe by snapping the perforation of the cap. This is done by bending the cap up and down until the perforation is broken. Do not touch the inside of the cap or the syringe tip. The diluent syringe may need to be recapped (if the dissolved Xyntha is not used immediately), so place the cap on its top on a clean surface in a spot where it would be least likely to become contaminated.



8. Lift the package away from the adapter and discard the package.

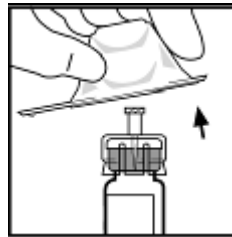

9. Place the vial on a flat surface. Connect the diluent syringe to the vial adapter by inserting the tip of the syringe into the adapter opening while firmly pushing and turning the syringe clockwise until the connection is secured.

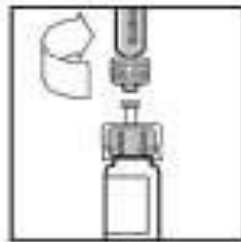

10. Slowly depress the plunger rod to inject all the diluent into the Xyntha vial.

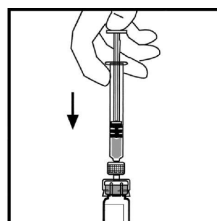

11. With the syringe still connected to the adapter, gently swirl the contents of the vial until the powder is dissolved.
Note: The final solution should be inspected visually for particulate matter before administration. The solution should be clear to slightly pearly and colorless. If it is not, the solution should be discarded and a new kit should be used.
12. Ensuring that the syringe plunger rod is still fully depressed, invert the vial. Slowly draw the solution into the syringe.

Note: If you prepared more than one vial of Xyntha, remove the diluent syringe from the vial adapter, leaving the vial adapter attached to the vial. Quickly attach a separate large luer lock syringe and draw back the dissolved contents as instructed above. Repeat this procedure with each vial in turn. Do not detach the diluent syringes or the large luer lock syringe until you are ready to attach the large luer lock syringe to the next vial adapter.

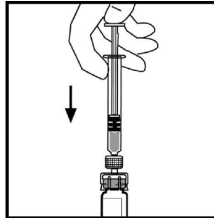

13. Detach the syringe from the vial adapter by gently pulling and turning the syringe counterclockwise. Discard the vial with the adapter attached.

Note: If the solution is not to be used immediately, the syringe cap should be carefully replaced. Do not touch the syringe tip or the inside of the cap.

Xyntha should be infused within 3 hours after dissolving. The dissolved solution may be stored at room temperature prior to infusion.

Xyntha Solofuse:

1. Allow the prefilled dual-chamber syringe of freeze-dried Xyntha to reach room temperature.
2. Remove the contents of the Xyntha Solofuse Kit and place on a clean surface, making sure you have all the supplies you will need.
3. Grasp the plunger rod as shown in the following diagram. Avoid contact with the shaft of the plunger rod. Screw the plunger rod firmly into the opening in the finger rest of the Xyntha Solofuse by pushing and turning firmly until resistance is felt (approximately 2 turns).

Note: Once the white tamper-evident seal is removed it is important to keep the Xyntha Solofuse in the upright position throughout the reconstitution process to prevent possible leakage. Throughout the reconstitution process, it is important to keep the Xyntha Solofuse upright to prevent possible leakage.

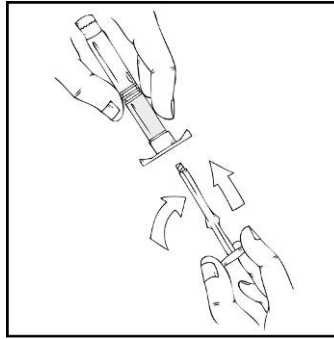

4. Holding the Xyntha Solofuse upright, remove the white tamper-evident seal by bending the seal right to left (or a gentle rocking motion) to break the perforation of the cap and expose the grey rubber tip cap of the Xyntha Solofuse.

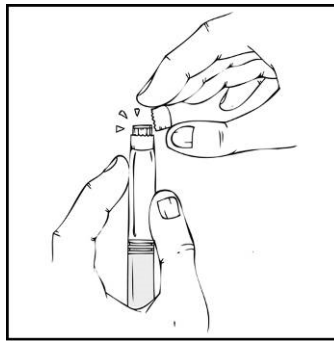

5. Remove the protective blue vented sterile cap from its package. While holding the Xyntha Solofuse upright, remove the grey rubber tip cap and replace it with the protective blue vented cap (prevents pressure build-up). Avoid touching the open end of both the syringe and the protective blue vented cap.

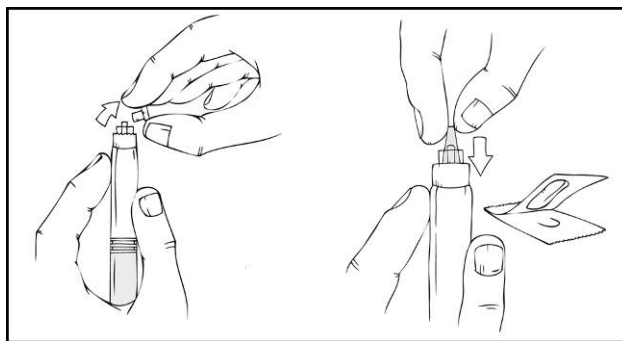

6. **Gently and slowly** advance the plunger rod by pushing until the two stoppers inside the Xyntha Solofuse meet, and all of the diluent is transferred to the chamber containing the Xyntha powder.

Note: To prevent the escape of fluid from the tip of the syringe, the plunger rod should not be pushed with excessive force.

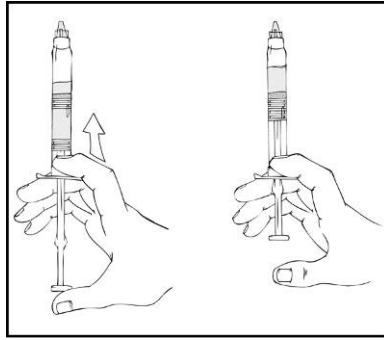

7. With the Xyntha Solofuse remaining upright, swirl gently several times until the powder is dissolved.

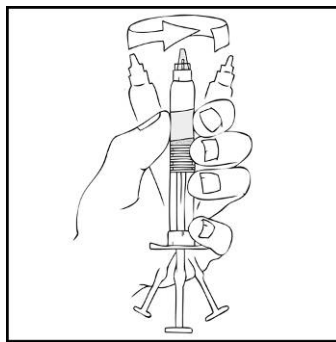

Note: The final solution should be inspected visually for particulate matter before administration. The solution should be clear to slightly pearly and colorless. If it is not, the solution should be discarded and a new kit should be used.

8. Again, holding the Xyntha Solofuse in an upright position, slowly advance the plunger rod until most, but not all, of the air is removed from the drug product chamber.

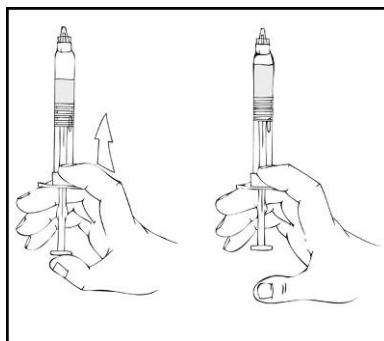

The reconstituted solution may be stored at room temperature prior to administration, but should be administered within 3 hours after reconstitution or removal of the grey rubber tip cap. If the solution is not used immediately, the syringe should be stored upright and the protective blue vent cap should remain on the Xyntha Solofuse until ready to infuse.

Infusion (Intravenous Injection)

Xyntha, when reconstituted, contains polysorbate-80, which is known to increase the rate of di- (2-ethylhexyl) phthalate (DEHP) extraction from polyvinyl chloride (PVC). This should be considered during the preparation and administration of Xyntha, including storage time elapsed in a PVC container following reconstitution. It is important that the recommendations in DOSAGE AND ADMINISTRATION section be followed closely.

Note: The tubing of the infusion set included with Xyntha vial kit and Xyntha Solofuse kit does not contain DEHP.

Xyntha Vial kit:

You should inject Xyntha as instructed by your hemophilia doctor or nurse. Once you learn how to self-infuse, you can follow the instructions in this insert.

Always wash your hands before doing the following procedures. Germ-free methods should be used during injection.

Xyntha should be administered using the pre-filled diluent syringe provided or a single sterile disposable plastic luer-lock syringe. In addition, the solution should be withdrawn from the vial using the vial adapter.

1. Attach the syringe to the luer end of the provided infusion set tubing and perform venipuncture as instructed by your hemophilia doctor or nurse.
2. Apply a tourniquet and prepare the injection site by wiping the skin well with an alcohol swab provided in the kit.



3. Insert the needle on the infusion set tubing into the vein, and remove the tourniquet. Infuse the reconstituted Xyntha product over several minutes. Your comfort level should determine the rate of infusion.

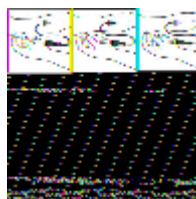

4. After injecting Xyntha, remove the infusion set and discard. The amount of drug product left in the infusion set will not affect your treatment. Dispose of all unused solution, the empty vial(s), and the used needles and syringes in an appropriate sharps container used for throwing away waste that might hurt others if not handled

properly.

You should record the lot number of the product every time you use Xyntha. The lot number can be found on the vial label. The peel-off label on the vial may be used to record the lot number.

In the absence of incompatibility studies, reconstituted Xyntha should not be administered in the same tubing or container with other medicinal products. Infusion kit components supplied in this carton are compatible with Xyntha for administration.

The reconstituted Xyntha solution does not contain a preservative and should be used within 3 hours of reconstitution.

Xyntha Solofuse:

Xyntha is administered by intravenous (IV) infusion after reconstitution of the freeze-dried powder with the diluent (0.9% Sodium Chloride). Both the Xyntha powder and the diluent are supplied within the prefilled dual-chamber syringe. Parenteral drug products should be inspected for particulate matter and discoloration prior to administration, whenever solution and container permit.

Xyntha, as provided in the prefilled dual-chamber syringe, should routinely be administered using the infusion set included in the kit.

1. After removing the protective blue vented cap, firmly attach the intravenous infusion set provided onto the Xyntha Solofuse.

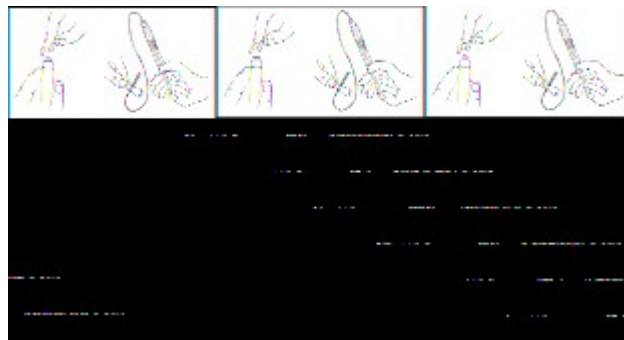

2. Apply a tourniquet and prepare the injection site by wiping the skin well with an alcohol swab provided in the kit.
3. Remove the protective needle cover and perform venipuncture. Insert the needle on the infusion set tubing into the vein, and remove the tourniquet. The reconstituted Xyntha product should be injected intravenously over several minutes. The rate of administration should be determined by the patient's comfort level. As with any intravenous administration, always verify proper needle placement.

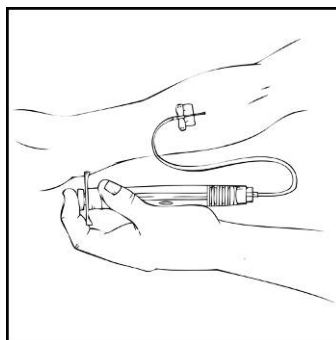

Reconstituted Xyntha should not be administered in the same tubing or container with other medicinal products.

4. After infusing Xyntha, remove the infusion set and discard. The amount of drug product left in the infusion set will not affect treatment.

Note: Dispose of all unused solution, the empty Xyntha Solofuse, and other used medical supplies in an appropriate container for throwing away medical waste that might hurt others if not handled properly.

Combined Use of a Xyntha Vial Kit and a Xyntha Solofuse Kit

Combined Use of a Xyntha Vial Kit and a Xyntha Solofuse Kit

These instructions are for the combined use of only one Xyntha vial kit and one Xyntha Solofuse Kit.

1. Reconstitute the Xyntha vial using the instructions included with the kit. Detach the empty diluent syringe from the vial adapter by gently turning and pulling the syringe counterclockwise, leaving the contents in the vial and the vial adapter in place.

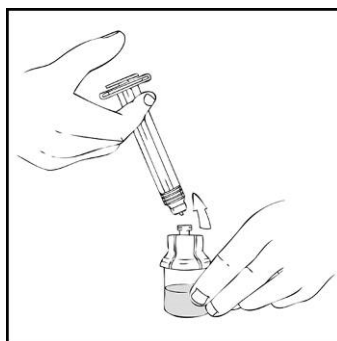

2. Reconstitute the Xyntha Solofuse using the instructions included with the kit, remembering to remove most, but not all, of the air from the drug product chamber.

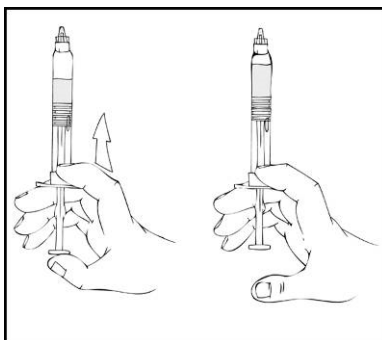

3. After removing the protective blue vented cap, connect the Xyntha Solofuse to the vial adapter by inserting the tip into the adapter opening while firmly pushing and turning the syringe clockwise until secured.

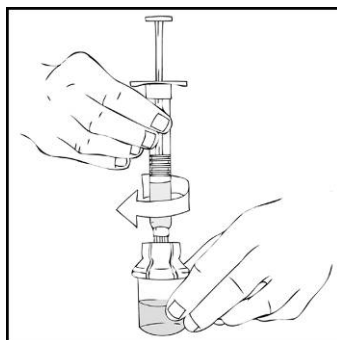

4. Slowly depress the plunger rod of the Xyntha Solofuse until the contents empty into the Xyntha vial. The plunger rod may move back slightly after release.

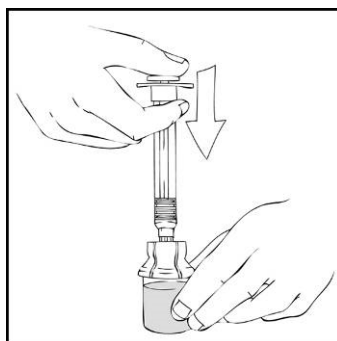

5. Detach and discard the empty Xyntha Solofuse from the vial adapter.

Note: If the syringe turns without detaching from the vial adapter, grasp the white collar and turn.

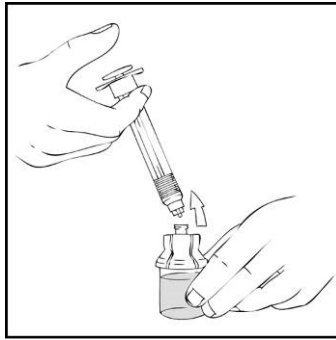

6. Connect a sterile 10 cc or larger luer lock syringe to the vial adapter. You may want to inject some air into the vial to make withdrawing the vial contents easier.

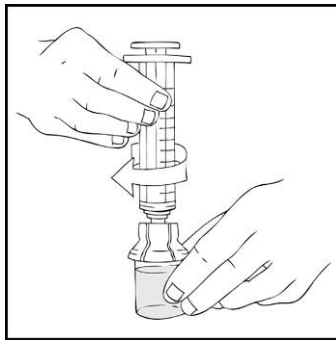

7. Invert the vial and slowly draw the solution into the 10 cc or larger luer lock syringe.

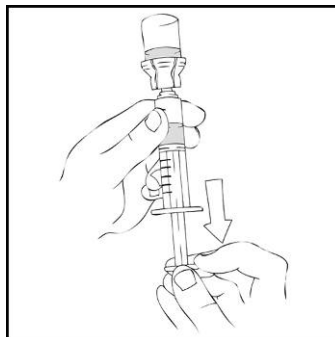

8. Detach the syringe from the vial adapter by gently turning and pulling the syringe counterclockwise. Discard the vial with the adapter attached.
9. Attach the infusion set to the 10 cc or larger luer lock syringe as directed (**see DOSAGE AND ADMINISTRATION**)

Note: Dispose of all unused solution, the empty Xyntha Solofuse, and other used medical supplies in an appropriate container for throwing away medical waste that might hurt others if not handled properly.

Multiple Xyntha Solofuse Reconstitution to a 10 cc or Larger Luer Lock Syringe

The instructions below are for the use of multiple Xyntha Solofuse kits with a 10 cc or larger luer lock syringe.

Note: Luer-to-luer syringe connectors are not provided in these kits. Instruct patients to contact Pfizer for information on how to obtain the Luer-to-luer syringe connectors.

1. Reconstitute all Xyntha Solofuse according to instructions shown above (see Dosage and Administration).

Holding the Xyntha Solofuse in an upright position, slowly advance the plunger rod until most, but not all, of the air is removed from the drug product chamber.

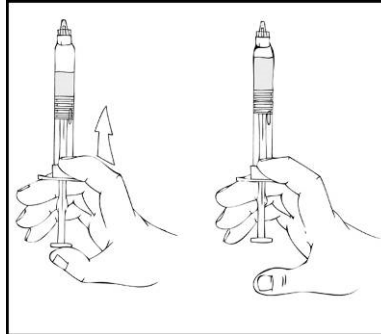

2. Remove the luer-to-luer syringe connector from its package.
3. After removing the protective blue vented cap, connect a sterile 10 cc or larger luer lock syringe to one opening (port) in the syringe connector and the Xyntha Solofuse to the remaining open port on the opposite end.

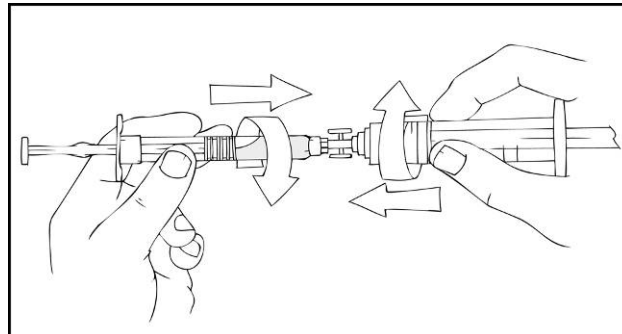

4. With the Xyntha Solofuse on top, slowly depress the plunger rod until the contents empty into the 10 cc or larger luer lock syringe.

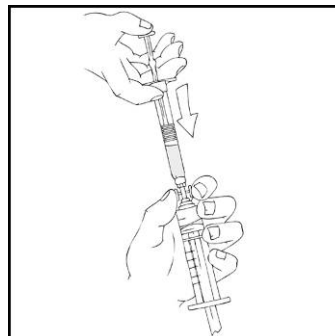

5. Remove the empty Xyntha Solofuse and repeat procedures 3 and 4

above for any additional reconstituted syringes.

6. Remove the luer-to-luer syringe connector from the 10 cc or larger luer lock syringe and attach the infusion set as directed (see Dosage and Administration).

Note: Dispose of all unused solution, the empty Xyntha Solofuse, and other used medical supplies in an appropriate container for throwing away medical waste that might hurt others if not handled properly

4.3 Contraindications

Xyntha may be contraindicated in patients with a known hypersensitivity to any of the constituents of the preparation.^z

Xyntha has not been studied in patients with a known history of hypersensitivity to hamster proteins and may be contraindicated in these patients.

4.4 Special warnings and precautions for use

Serious Warnings and Precautions

Anaphylaxis and severe hypersensitivity reactions are possible as with any intravenous protein product. Should such reactions occur, treatment with the product should be discontinued and appropriate treatment should be administered.

Development of activity-neutralizing antibodies has been detected in patients receiving factor VIII-containing products. If expected plasma factor VIII activity levels are not attained, or if bleeding is not controlled with an appropriate dose, an assay that measures factor VIII inhibitor concentration should be performed.

General

It is recommended that, whenever possible, every time that Xyntha is administered to patients the lot number of the product is documented.

Immune

The occurrence of neutralizing antibodies (inhibitors) is well known in patients receiving factor VIII-containing products. Inhibitors most commonly occur early in the treatment course of previously untreated patients, but have also been observed in patients who have previously received large amounts of factor VIII products. All patients using coagulation factor VIII

products, including Xyntha, should be monitored periodically for the development of factor VIII inhibitors. In patients with inhibitors (especially high level inhibitors, above 5 Bethesda units (BU)/mL), factor VIII therapy may not be effective, and other therapeutic options should be considered. In addition, if expected factor VIII activity plasma levels are not attained, or if bleeding is not controlled with an appropriate dose, testing should be performed to determine if a factor VIII inhibitor is present. Management of such patients should be directed by physicians with experience in the care of patients with hemophilia.

Hypersensitivity

As with any intravenous protein product, allergic type hypersensitivity reactions are possible. Patients should be informed of the early signs or

symptoms of hypersensitivity reactions including hives (rash with itching), generalized urticaria, tightness of the chest, wheezing, and hypotension.

If allergic or anaphylactic reactions occur, administration of Xyntha should be stopped immediately, and appropriate medical management should be given, which may include treatment for shock. Patients should be advised to discontinue use of the product and contact their hemophilia physicians and/or seek immediate emergency care, depending on the type and severity of the reaction, if any of these symptoms occur.

4.5 Interaction with other medicinal products and other forms of interaction

No interactions with other medicinal products are known.

4.6 Fertility, pregnancy, and lactation

Pregnancy and Lactation:

No animal reproduction and lactation studies have been conducted with Xyntha. Based on the rare occurrence of hemophilia A in women, experience regarding the use of factor VIII during pregnancy is not available. Xyntha should be administered to pregnant and lactating women only if the benefit outweighs the risk.

Pediatric:

Xyntha is appropriate for use in children of all ages, including newborns.

Safety and efficacy studies have been performed both in previously treated children and adolescents (N=98, ages 7-18 years) and in previously untreated neonates, infants, and children

(N=101, ages 0-52 months). There are no clinical data of previously untreated patients (PUPs) treated with ReFacto AF or XYNTHA. An additional ongoing clinical study is evaluating the use of Xyntha in previously treated subjects under 6 years of age with moderately severe to severe hemophilia A.

Geriatrics (≥ 65 years of age):

Clinical studies of Xyntha did not include sufficient numbers of subjects aged 65 and over to determine whether they respond differently from younger subjects. Other reported clinical experience with factor VIII products has not identified differences in responses between the elderly and younger patients. As with any patient receiving Xyntha, dose selection for an elderly patient should be individualized.

4.7 Effects on ability to drive and use machines.

No studies on the ability to drive and use machines have been performed

4.8 Undesirable effects

System Organ Class (disorder)	Very Common ≥10%	Common ≥1%	Uncommon ≥0.1% and <1%	Rare ≥0.01% and <0.1%	Very Rare <0.01%
Immune system disorders					Anaphylactoid reaction
Cardiac disorders					Angina pectoris, tachycardia, palpitations*
Investigations				Lab increase for antibody to Mouse IgG (ReFacto only), Lab increase of FVIII antibody, Lab increase for antibody to CHO protein,	CPK increased, Increased aspartate aminotransferase, Increased alanine aminotransferase* Increased bilirubin
Nervous system disorders				Headache, Dizziness	Neuropathy*, Perspiration increased, Somnolence, Taste altered
Metabolism & nutrition disorders					Anorexia
Musculoskeletal and connective tissue disorders				Arthralgia	Myalgia
Vascular disorders				Hemorrhage, hematoma	Flushing*, Thrombophlebitis* Hypotension, Vasodilation
Respiratory, thoracic & mediastinal disorders				Cough	Dyspnea
Gastrointestinal disorders				Vomiting*, Nausea, Diarrhea, Abdominal pain	
Skin and subcutaneous tissue disorders				Rash	Pruritis, Urticaria
General disorder & administration site conditions				Pyrexia, Chills, catheter site related reaction	Asthenia Injection site pain Injection site reaction, Injection site inflammation*

Factor VIII Inhibitor n†	FVIII Inhibitor PUPS	FVIII Inhibitor PTPS			
--------------------------	----------------------	----------------------	--	--	--

(*) = These adverse reactions were totaled from adverse events and hemophilia events across all studies regardless of relatedness to study drug.

All other adverse reactions were totaled across all studies from study drug-related adverse events and hemophilia events ONLY

For the adverse reaction frequencies, surgical patients receiving continuous infusion (CI), any day CI is administered is considered one infusion.

(†) = Frequency for the Adverse Reaction Factor VIII inhibition is expressed on a per patient basis

The most frequently reported treatment-emergent adverse reaction, on a per infusion basis, was vomiting. Most adverse reactions reported were considered mild or moderate in severity.

In addition, as with any intravenous protein product, allergic type hypersensitivity reactions are possible. Manifestations of hypersensitivity reactions may include hives, generalized urticaria, tightness of the chest, wheezing, hypotension, and anaphylaxis.

Patients with hemophilia A may develop neutralizing antibodies (inhibitors) to factor VIII. As with all coagulation factor VIII products, patients are to be monitored for the development of inhibitors that are quantified in Bethesda Units (BUs) using either the Bethesda assay or Bethesda assay with the Nijmegen modification. If such inhibitors occur, the condition may manifest itself as an insufficient clinical response or an unexpectedly low yield of plasma factor VIII activity. In such cases, it is recommended that a specialized hemophilia center be contacted.

Reports of lack of effect, mainly in prophylaxis patients, have been received during the clinical trials and post-marketing setting. The lack of effect and/or low factor VIII recovery has been reported in patients with inhibitors but also in patients who had no evidence of inhibitors. The lack of effect has been described as bleeding into target joints, bleeding into new joints, other bleeding or a subjective feeling by the patient of a new onset bleeding. In order to ensure an adequate therapeutic response, it is important TO INDIVIDUALLY TITRATE AND MONITOR each patient's dose of Xyntha, particularly when initiating treatment with Xyntha (see WARNINGS AND PRECAUTIONS and DOSAGE AND ADMINISTRATION).

If any reaction takes place that is thought to be related to the administration of Xyntha, the rate of infusion should be decreased or the infusion stopped, as dictated by the response of the patient.

In a clinical trial (Study 301), 32 out of 101 (32%) previously untreated patients treated with Xyntha manufactured by the previous process developed inhibitors: 16 out of 101 (16%) with a titer >5 Bethesda Units (BU) and 16 out of 101 (16%) with a titer ≤5 BU. The median number of exposure days prior to inhibitor development in these patients was 12 days (range 3 - 49 days). Of the 16 high responder patients, 15 received immune tolerance (IT) treatment. Eleven (11) of the high responders had a titer of <0.6 BU at their latest available test after IT. In addition, IT treatment was started in 10 of the 16 low titer (≤5 BU)

patients, 9 of whom had titer <0.6 BU for their latest value. Therefore, IT had an overall efficacy of 80% (20/25), 73% for high-responders and 90% for low-responders. Five (5) of the 6 remaining low responder patients who did not receive IT also had a titer <0.6 BU for their latest value.

In a clinical trial of Xyntha manufactured by the previous process, one of 113 (0.9%) previously heavily treated patients who were evaluated for efficacy in bleeding episodes developed a high titer inhibitor. Inhibitor development in this patient occurred in the same time frame as the development of monoclonal gammopathy of uncertain significance. The patient was noted initially at a local laboratory to have a treatment-emergent low titer inhibitor at 98 exposure days, which was confirmed at 2 BU at the central laboratory at 113 exposure days. After 18 months on continued treatment with Xyntha, the inhibitor level rose to nearly 13 BU and a bleeding episode failed to respond to Xyntha treatment.

In a pivotal phase 3 study, in which previously treated patients (PTPs) with hemophilia A received Xyntha for routine prophylaxis and on-demand treatment, 94 subjects received at least one dose of Xyntha resulting in a total of 6775 infusions. In this study, the incidence of FVIII inhibitors to Xyntha was the primary safety endpoint. Two patients with low titer, transient inhibitors were observed in these 94 patients (2.1%). In a Bayesian statistical analysis, results from this study (two out of 94 subjects developed an inhibitor, 89 had 50 or more exposure days to XYNTHA) were used to update PTP results from prior supporting studies of Xyntha. This Bayesian analysis indicates that the population (true) inhibitor rate for Xyntha was below a predefined acceptable value of 4.4%; the estimate of the 95% upper limit of the true inhibitor rate was 4.07%.

In a pivotal phase 3 study for surgical prophylaxis in patients with hemophilia A (study 311), one low titer persistent inhibitor and one transient false-positive inhibitor were reported.

There have been spontaneous postmarketing reports of high titer inhibitors developing in previously treated patients.

Laboratory increases in anti-FVIII antibody titers, in the absence of inhibitor development, have been observed in clinical trials. In a study of PTPs receiving XYNTHA for routine treatment and prevention of bleeding episodes (study 310) and for surgical prophylaxis (study 311), 1 of 94 (1%) patients, and 1 of 30 (3%) patients, respectively, developed anti-FVIII antibodies; these patients did not develop an inhibitor. The clinical significance of these antibodies, in the absence of an inhibitor, is unclear.

In clinical trials of PTPs receiving XYNTHA for routine treatment and prevention of bleeding episodes, 0 of 94 (0%) patients in study 310, and 3 of 110 (3%) patients in study 306/307, developed a lab increase in anti-CHO (Chinese hamster ovary, the cell line which is the source of factor VIII for XYNTHA) antibody titer, without any apparent clinical effect. In a study of XYNTHA for surgical prophylaxis (study 311) 1 of 30 (3%) patients developed a lab increase for antibody to CHO. Twenty of 113 (18%) previously treated patients (PTPs) had an increase in anti-

CHO (Chinese hamster ovary, the cell line which is the source of factor VIII for Xyntha) antibody titer, without any apparent clinical effect.

Reporting of suspected adverse reactions: Healthcare professionals are asked to report any suspected adverse reactions via pharmacy and poisons board, Pharmacovigilance Electronic Reporting System (PvERS) <https://pv.pharmacyboardkenya.org>

4.9 Overdose

No symptoms case of overdose have been reported with coagulation factor VIII products.

5. Pharmacological properties

5.1 Pharmacodynamic properties

Mechanism of Action

Xyntha is a glycoprotein with an approximate molecular mass of 170 000 Da consisting of 1438 amino acids. Xyntha is a recombinant DNA-based substance which has functional characteristics comparable to those of endogenous factor VIII. Activated factor VIII acts as a cofactor for activated factor IX accelerating the conversion of factor X to activated factor X. Activated factor X converts prothrombin into thrombin. Thrombin then converts fibrinogen into fibrin which forms an insoluble clot.

Pharmacodynamics

Factor VIII is the specific clotting factor deficient in patients with hemophilia A (classical hemophilia). The administration of Xyntha, Antihemophilic Factor (Recombinant)[BDDrFVIII] increases plasma levels of factor VIII and can temporarily correct the coagulation defect in these patients.

5.2 Pharmacokinetic properties

One Stage Assay

In a pivotal cross-over pharmacokinetic study, Xyntha was shown to be bioequivalent to another recombinant factor VIII product (rFVIII, Advate®) in 30 previously treated patients (PTPs) (□ 12 years) using the one-stage clotting assay. The ratios of geometric least square means of Xyntha - to-Advate® were 100%, 89.8% and 88.0% for K-value, AUC_t and AUC_∞, respectively. The corresponding 90% confidence intervals about the ratios of Xyntha to Advate® geometric means were within the bioequivalence window of 80% to 125%, demonstrating bioequivalence of Xyntha to Advate®.

In the same study, the pharmacokinetic parameters for Xyntha were determined at baseline and followed-up in 25 PTPs (≥12 years) after repeated administration of Xyntha for six months. At baseline, following a single 2-minute intravenous infusion of 50 IU/kg dose of Xyntha, plasma FVIII:C increased sharply with a mean (±SD) C_{max} of 1.12 (±0.19) IU/mL. Thereafter, the decline of FVIII:C exhibited biphasic disposition characteristics. In the initial phase, the activity dropped at

a rate consistent with relatively rapid but limited distribution into extravascular space. The mean (\pm SD) steady-state volume of distribution was 65.1 (\pm 35.1) mL/kg. During the terminal phase, the rate of decline in FVIII:C was slower than the initial phase with a mean (\pm SD) terminal elimination half-life of 11.8 (\pm 5.1) hours. A comparable pharmacokinetic profile was obtained after repeated use for six months. The ratios of geometric least square means of month 6-to-baseline pharmacokinetic were 107%, 100% and 104% for recovery, AUC_t and AUC_∞, respectively. No time-dependent changes in the pharmacokinetic properties of Xyntha were observed (Table 3).

Figure -1: Xyntha vs. Advate

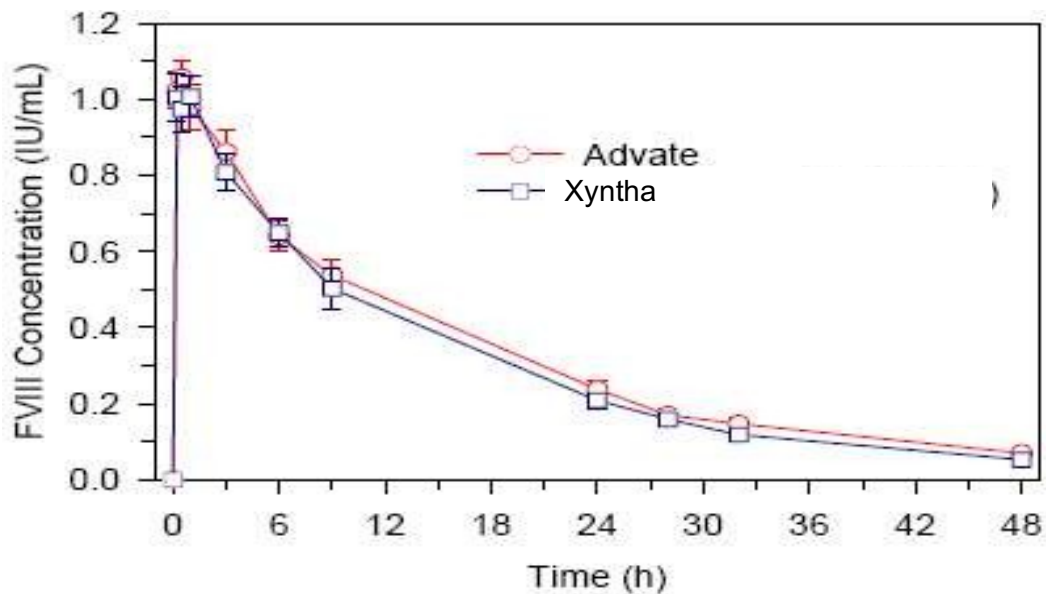

In the same study, the pharmacokinetic parameters for Xyntha were determined at baseline and followed-up in 25 PTPs (\geq 12 years) after repeated administration of Xyntha for six months. At baseline, following a single 2-minute intravenous infusion of 50 IU/kg dose of Xyntha, plasma FVIII:C increased sharply with a mean (\pm SD) C_{max} of 1.12 (\pm 0.19) IU/mL. Thereafter, the decline of FVIII:C exhibited biphasic disposition characteristics. In the initial phase, the activity dropped at a rate consistent with relatively rapid but limited distribution into extravascular space. The mean (\pm SD) steady-state volume of distribution was 65.1 (\pm 35.1) mL/kg. During the terminal phase, the rate of decline in FVIII:C was slower than the initial phase with a mean (\pm SD) terminal elimination half-life of 11.8 (\pm 5.1) hours. A comparable pharmacokinetic profile was obtained after repeated use for six months. The ratios of geometric least square means of month 6-to-baseline pharmacokinetic were 107%, 100% and 104% for recovery, AUC_t and AUC_∞, respectively. No time-dependent changes in the pharmacokinetic properties of Xyntha were observed (Table 3).

TABLE 3 MEAN FACTOR VIII PHARMACOKINETIC PARAMETERS FOR 25 PTPS FOLLOWING A RAPID INFUSION OF XYNTHA AT A DOSE OF 50 IU/KG

Parameter	C _{max} (IU/ml)	AUC _t (hr*IU/ml)	Half-life (hr)	AUC _∞ (hr*IU/ml)	Clearance (ml/hr/kg)	Mean Residence Time (hr)	V _{ss} (ml/kg)	Recovery (IU/dl/IU/kg)
Baseline								
Mean	1.12	13.3	11.8	14.2	4.21	16.3	65.1	2.23
SD	0.19	5.2	5.1	5.5	2.08	5.9	35.1	0.39
Min	0.59	4.1	6.4	4.7	2.00	7.9	34.8	1.19
Max	1.41	23.6	33.9	25.0	10.63	40.0	195.1	2.83

TABLE 3 MEAN FACTOR VIII PHARMACOKINETIC PARAMETERS FOR 25 PTPS FOLLOWING A RAPID INFUSION OF XYNTHA AT A DOSE OF 50 IU/KG

Parameter	C _{max} (IU/ml)	AUC _t (hr*IU/ml)	Half-life (hr)	AUC _∞ (hr*IU/ml)	Clearance (ml/hr/kg)	Mean Residence Time (hr)	V _{ss} (ml/kg)	Recovery (IU/dl/IU/kg)
Month 6								
Mean	1.24	13.3	11.8	15.0	4.04	19.5	67.4	2.47
SD	0.42	6.7	6.2	7.5	1.87	16.1	32.6	0.84
Min	0.65	5.0	5.8	5.3	1.19	7.6	18.5	1.29
Max	2.60	41.0	32.6	14.8	9.45	89.2	168.8	5.20

Abbreviations: AUC_∞ = area under the plasma concentration-time curve from time zero to infinity; AUC_t = area under the plasma concentration-time curve from zero to the last measurable concentration; C_{max} = peak concentration; SD=standard deviation; V_{ss}=volume of distribution at steady-state

In a pivotal phase III study (Study 311) for surgical prophylaxis, XYNTHA pharmacokinetics were evaluated during the perioperative management of patients with hemophilia A who were undergoing major surgery. At the baseline visit, all patients received a single dose of XYNTHA of approximately 50 IU/kg. Plasma samples were analyzed for FVIII activity using a validated one-stage (OS) clotting method. Recovery data are available for a total of 30 patients; the mean (□ standard deviation [SD]) K-value was 2.11(□ 0.43) IU/dL per IU/kg, and the mean (±SD) in vivo recovery value was 101.0% (□ 20%).

Chromogenic Assay

The labeled potency of Xyntha manufactured by the previous process is based on the European Pharmacopoeia chromogenic substrate assay in which the Pfizer In-House Recombinant Factor VIII Potency Reference

Standard has been calibrated to the WHO International Standard using the chromogenic substrate assay.

In a crossover pharmacokinetic study of eighteen (18) previously treated patients using the chromogenic assay, the circulating mean half-life for Xyntha manufactured by the previous process was 14.8 ± 5.6 hours (ranged from 7.6 - 28.5 hours), which was not statistically significantly different from plasma-derived Antihemophilic Factor (Human), (pdAHF), which had a mean half-life of 13.7 ± 3.7 hours (ranged from 8.8 - 25.1 hours). Mean incremental recovery (K-value) of Xyntha manufactured by the previous process in plasma was 2.4 ± 0.4 IU/dL per IU/kg (ranged from 1.9 - 3.3 IU/dL per IU/kg). This was comparable to the mean incremental recovery observed in plasma for pdAHF which was 2.3 ± 0.3 IU/dL per IU/kg (ranged from 1.7 - 2.9 IU/dL per IU/kg). In additional clinical studies using Xyntha manufactured by the previous process, pharmacokinetic parameters measured using the chromogenic assay were determined for previously treated patients (PTPs) and previously untreated patients (PUPs). In PTPs (n=101; median age 26 ± 12 years), Xyntha manufactured by the previous process had a recovery at Week 0 of 2.4 ± 0.4 IU/dl per IU/kg (range 1.1 to 3.8 IU/dl per IU/kg). In measurements over 4 years of use (Month 3 [n=90], Month 6 [n=87], Month 12 [n=88], Month 24 [n=70], Month 36 [n=64] and Month 48 [n=52]), the mean incremental recovery was reproducible and ranged from 2.3 to 2.5 IU/dl per IU/kg. A subset of 37 study subjects had evaluable pharmacokinetic profiles at both baseline and Month 12. The 90% confidence intervals for the ratios of the mean values of Month 12-to-baseline AUCT, AUC_{0-∞}, and K-value were well within the bioequivalence window of 80% to 125%, demonstrating the stability of these pharmacokinetic parameters over 1 year. In PUPs (n=59; median age 10 ± 8.3 months), Xyntha manufactured by the previous process had a mean recovery at Week 0 of 1.5 ± 0.6 IU/dl per IU/kg (range 0.2 to 2.8 IU/dl per IU/kg). The mean incremental recovery for PUPs was stable over time (5 visits during a 2-year period) and ranged from 1.5 to 1.8 IU/dL per IU/kg of Xyntha manufactured by the previous process. Population pharmacokinetic modeling using data from 44 PUPs led to a mean estimated half-life of Xyntha manufactured by the previous process in PUPs of 8.0 ± 2.2 hours.

Table 4: Mean Factor VIII Pharmacokinetic Parameters for 37 PTPS with Both Baseline and Month 12 Pharmacokinetic Profiles Following A Rapid Infusion of Xyntha manufactured by the previous process at a Dose of 50 IU/KG

Parameter	Cmax (IU/ml)	AUCT (hr*IU/ml)	Half-life (hr)	AUC _{0-∞} (hr*IU/ml)	Clearance (ml/hr/kg)	Mean Residence Time (hr)	V _{ss} (ml/kg)	K-value (IU/dl/IU/kg)
Baseline								
Mean	1.17	13.6	10.6	15.4	3.53	15.0	50.9	2.34
SD	0.24	3.4	2.5	4.5	1.03	3.4	13.0	0.49

Min	0.55	6.0	6.8	7.6	1.78	9.8	36.9	1.10
Max	1.90	21.1	17.2	28.1	6.60	24.7	99.0	3.80
Parameter	Cmax (IU/ml)	AUCT (hr*IU/ml)	Half-life (hr)	AUC _{0-∞} (hr*IU/ml)	Clearance (ml/hr/kg)	Mean Residence Time (hr)	Vss (ml/kg)	K-value (IU/dl/IU/kg)
Month 12								
Mean	1.20	14.0	11.4	16.5	3.37	16.1	51.1	2.40
SD	0.29	4.7	3.5	5.7	1.08	4.6	11.4	0.58
Min	0.84	7.8	6.6	8.8	1.49	9.7	21.3	1.67
Max	2.31	32.4	20.1	33.5	5.66	27.8	83.2	4.61

5.3 Preclinical safety data

Xyntha has been shown to be nonmutagenic in the mouse micronucleus assay. No other mutagenicity studies and no investigations on carcinogenesis, impairment of fertility or fetal development have been conducted.

6. Pharmaceutical particulars

6.1 List of excipients

Polysorbate 80 (0.4 mg/vial or prefilled dual-chamber syringe)
 Sucrose (12 mg/vial or prefilled dual-chamber syringe)
 L-Histidine (6 mg/vial or prefilled dual-chamber syringe)
 Calcium Chloride Dihydrate (1 mg/vial or prefilled dual-chamber syringe)
 Sodium Chloride (72 mg/vial or prefilled dual-chamber syringe) [after reconstitution with diluent].

6.2 Incompatibilities

Not Applicable

6.3 Shelf life

36 months

6.4 Special precautions for storage:

Xyntha Vial Kit:

Xyntha Antihemophilic Factor (Recombinant) should be stored under refrigeration at a temperature of 2° to 8°C. Xyntha vial may also be stored at room temperature not to exceed 25°C for up to 3 months. The diluent syringe should be stored at 2°C to 25°C and should not be used subsequent to expiration of the Xyntha drug product. The patient should write in the space provided on the outer carton the date the product was placed at room temperature. After room temperature storage, the product can be returned to refrigerated storage until the expiration date. Do not store Xyntha vial at room temperature and return it to refrigerated storage more than once. Do not use Xyntha vial after the expiry date on the label.

Xyntha Solofuse:

Xyntha Antihemophilic Factor (Recombinant) should be stored under refrigeration at a temperature of 2°C to 8°C C. Xyntha Solofuse may also be stored at room temperature not to exceed 25°C for up to 3 months. The patient should write in the space provided on the outer carton the date the product was placed at room temperature. After room temperature storage, the product can be returned to refrigerated storage until the expiration date. Do not store Xyntha at room temperature and return it to refrigerated storage more than once. Do not use Xyntha Solofuse after the expiry date on the label.

Xyntha Vial Kit:

Product after reconstitution: The reconstituted solution may be stored at room temperature prior to administration. The product does not contain a preservative and should be used within 3 hours.

Xyntha Solofuse:

Product after reconstitution: Xyntha should be infused within 3 hours after reconstitution or after removal of the grey rubber tip cap from the Xyntha Solofuse. The reconstituted solution may be stored at room temperature prior to infusion.

6.5 Nature and contents of container

Xyntha Vial Kit:

Xyntha, Antihemophilic Factor (Recombinant) freeze-dried is supplied in kits that include single-use vials that contain nominally 250, 500, 1000, or 2000 IU per vial. Actual factor VIII activity in IU is stated on the label of each Xyntha Antihemophilic Factor (Recombinant) vial.

In addition, each Xyntha Antihemophilic Factor (Recombinant) kit contains: one pre-filled diluent syringe containing 4 mL 0.9% Sodium Chloride with plunger rod for assembly, one vial adapter, one sterile infusion set, two alcohol swabs, one bandage, one gauze, and one package insert.

Xyntha Solofuse:

Xyntha Antihemophilic Factor (Recombinant), is supplied in a kit that includes the Xyntha freeze-dried powder that contain nominally 250, 500, 1000, 2000, or 3000 IU and 4 mL 0.9 % Sodium Chloride solution for reconstitution in a pre-filled dual-chamber syringe. Actual factor VIII activity in IU is stated on the label of each Xyntha Antihemophilic Factor (Recombinant) pre-filled dual-chamber syringe.

In addition, each Xyntha Antihemophilic Factor (Recombinant), Kit contains: one plunger rod for assembly, one sterile infusion set, two alcohol swabs, one bandage, one gauze pad, one vented sterile cap, and one package insert

6.6 Special precautions for disposal and other handling:

Freezing should be avoided to prevent damage to the pre-filled diluent syringe.

During storage, avoid prolonged exposure of Xyntha vial to light.

7. Marketing authorization holder and manufacturing site addresses

Marketing authorization holder:

Company Name: PFIZER LABORATORIES LIMITED
Address: P.O. BOX 8244 00500
Country: KENYA
Telephone: +254202839110
Telefax:N/A E-Mail: WWW.PFIZER.CO

Manufacturing site address:

Company Name: Wyeth Farma, S.A
Address: Autovía del Norte A-1 Km 23,Desvío Algete
Km1, 28700 San Sebastián de los
Reyes, Madrid
Country: Spain
Telephone: +4497615180
E-Mail: www.pfizer.com

Local Technical Representative:**8. Marketing authorization number**

CTD10083

9. Date of first registration

09/12/2023

10. Date of revision of the text:

14/09/2023

11. Dosimetry:

Not Applicable

12. Instructions for Preparation of Radiopharmaceuticals:

Not Applicable